

# DATASHEET PEANUT SHELLER

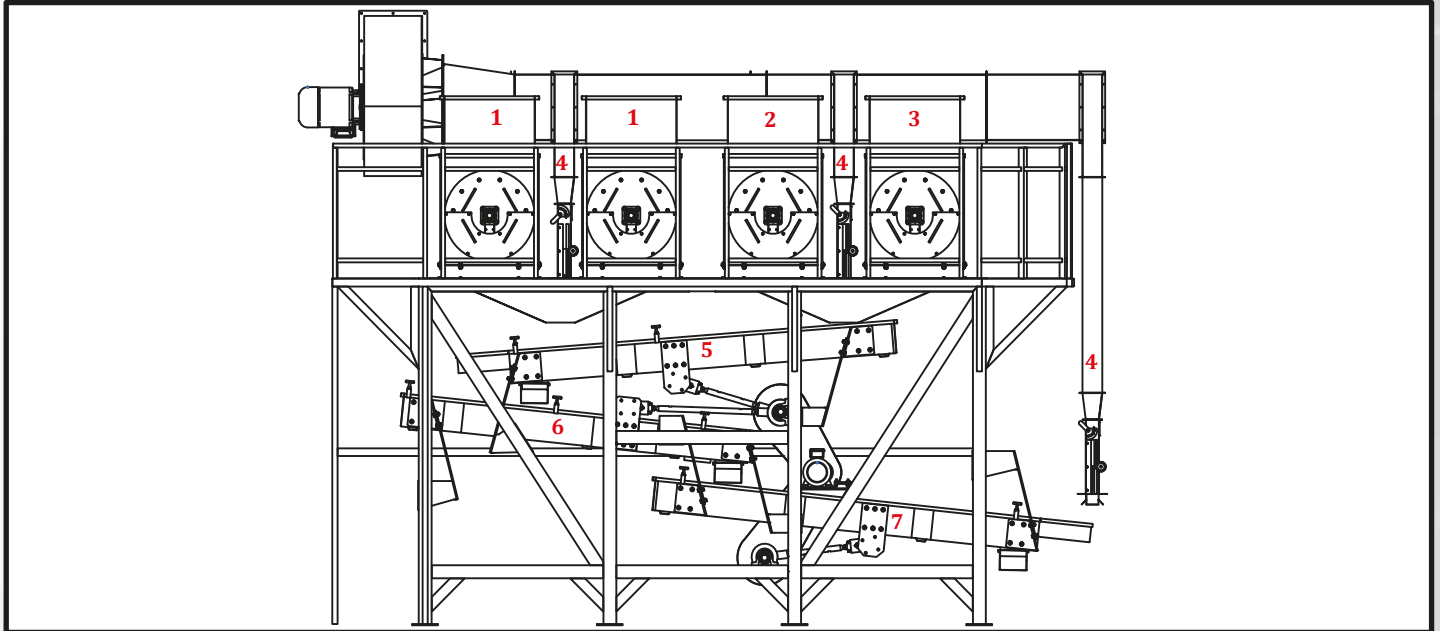

## 1- Main Sheller Cylinders:

1 or 2 sellers are used up to capacity requirement. Shelled peanuts fall onto first Screening boat (5).

## 2- Re-Sheller Cylinder:

In shell peanuts which is separated by screen boat (item number 6), conveyed to this Re-sheller via Bucket elevator and repeats shelling process.

## 3- Second Re-Sheller Cylinder:

In shell peanuts which is separated by Density Separator which is located after Peanut Sheller goes in to Second Sheller and repeats shelling process.

## 4- Vacuum Channels:

Right after Sheller Cylinders and at the final exit, most light shells separated via air aspiration system.

## 5- Screening Boat:

Shelled peanut and shell fall onto first screen for undersize separation task to remove small shells and admixtures which exits out from chute. Oversize main products are transferred to screen grader (6).

## 6- Screen Grader Boat:

Screen grader works ad sizer. Undersize in shell peanut conveyed into Re-Sheller Cylinder (2) via bucket elevator. Oversize main products fall into screen grader boat (7).

## 7- Screen Grader Boat:

This screen works for specified sizing for peanuts without shell which comes from first screen grader (6). Undersize peanuts taken out via chute. Oversize peanuts are transferred to elevator for the next process.

<b>Capacity:</b> (Maximum 15% Humidity)	
Inshell Ground Peanut	10.0-14.0 t/hr
<b>Dimensions:</b>	
Weight	7000 kg
Lenght	6350 mm
Width	3610 mm
Height	4300 mm
<b>Screen Area:</b>	11.0 m <sup>2</sup>
<b>Motors:</b> (standard):	
Aspirator Motor	11 kW
Eccentric Motor	2.2 kW
Sheller Motors	11 kW
Bunker Vibrating Motor	0,18 kW
<b>Air volume:</b>	
Machine Intake Air Volume	22500 m <sup>3</sup> /h

Technical data can vary for certain of the above due to continued development, or a different machine composition.



MMCTECH: Seed Machines & Equipment with Automation Solutions

www.mmctech.us

info@mmctech.us