



# MMCTECH

SEED PROCESSING MACHINE & EQUIPMENTS - AUTOMATION SOLUTIONS

[www.mmctech.us](http://www.mmctech.us)

[info@mmctech.us](mailto:info@mmctech.us)

## UNIVERSAL CLEANERS



Mmctech Seed Conditioning And Processing Global Solution

Product Code

# UNIVERSAL 240

# UNIVERSAL EXCELLPRE CLEANERS

## High Effective Pre-cleaning Performance

Akyurek Technology develops and manufactures solutions for pre-cleaning of all cereals, maize, rape seed, peas and similar products before drying or storage. Pre-cleaning differs from rough cleaning in the way that this process also is able to separate products smaller than the main crop.

The Akyurek Technology product range covers Akyurek Technology Excell Pre Cleaners, Aspirators and Akyurek Technology Combi Cleaners.

Akyurek Technology UniversalExcell Pre Cleaners are a versatile screen cleaner specifically designed for pre cleaning using a 5 - 15m<sup>2</sup> area in conjunction with a sophisticated aspiration system.

Pre-cleaning may replace rough cleaning when receiving a raw material from which, in addition to the large impurities, most of the sand, thin grain and weeds are to be separated. Pre-cleaners have capacities ranging from 5 to 100t/h. All these cleaners have effective pre-suction and after suction systems for separation of light products such as chaff, straw, light grain, etc.

## UNIVERSAL EXCELLPRE CLEANERS DISTINGUISHING FEATURES

### 1 FULL-WIDTH SHAKER FEEDER

- Has Infinitely Variable Adjustment Of The Feed Capacity Via A Separate Control Panel
- Ensures Uniform Flow Over The Entire Width Of The Screen
- Is Self-cleaning
- Considerably Improves Air Cleaning, Since The Product Hits The Pre-suction Area In A Uniform Manner
- Is Gentle With Respect To Leguminous Seeds, Paddy Rice Etc.
- Ensures Optimum Capacity Utilisation Of The Machine
- Ensures No Downtime Due To Blocked Inlets
- Requires No Cleaning When Changing Products

### 3 PRE-SUCTION AND POST-SUCTION SYSTEM

- Built As Two Separate Air Suction Units
- Can Be Connected To Existing Central Aspiration Systems Due To The Small Air Volume

### 5 SCREEN BOXES IN PLYWOOD COVERED WITH SWEDOTEX FILM

- Are Moisture-resistant And Insect-resistant, And Approved By The Food Industry
- Are Constructed With Replaceable Wear Plates And Screen Runners In Exposed Areas
- Have A Long Lifetime Due To The Fact That The Plywood Easily Copes With The Vibrations Of The Screen Box
- Give Less Resonance Owing To The Use Of Plywood, Thus Resulting In A Better Working Environment

### 2 FEED ROLLER

- Has An Adjustable Capacity Shutter In Combination With infinitely Variable Speed Control Of The Feed Roller, Which Controls The Feed Capacity
- Is Not Affected By Lightweight Waste Material And Large Impurities Such As Stones, Etc.
- Has A Built-in Spring-loaded Safety Device Which Protects The Feed Roller Against Damage

### 4 SCREW CONVEYOR OUTLET FOR LIGHTWEIGHT WASTE

- Ensures Continuous Discharge Of Dust And Waste From The Air System Via Screw Conveyors
- Has Finger Flaps To Ensure Optimal Dust Separation In The Expansion Chamber By Preventing False Air From Entering The Chamber

### 6 DISTRIBUTOR

- Ensures 50% Distribution Of The Grain Flow Via The Top And Bottom Screen Boxes Respectively
- 50% And 33% Distributors Ensure Distribution Of The Grain Flow In Each Screen Box Between Various Screen Rows

### 7 CHANGE OF SCREEN INCLINATION

- Allows Different Capacity And Cleaning Result.
- Ensures Excellent Purity And Minimum Waste
- Is Easily Carried Out By Changing The Screen Hangers.
- The Machine Can Be Used As A Pre-cleaner, Industrial Cleaner Or Fine Cleaner

# UNIVERSAL CLEANERS

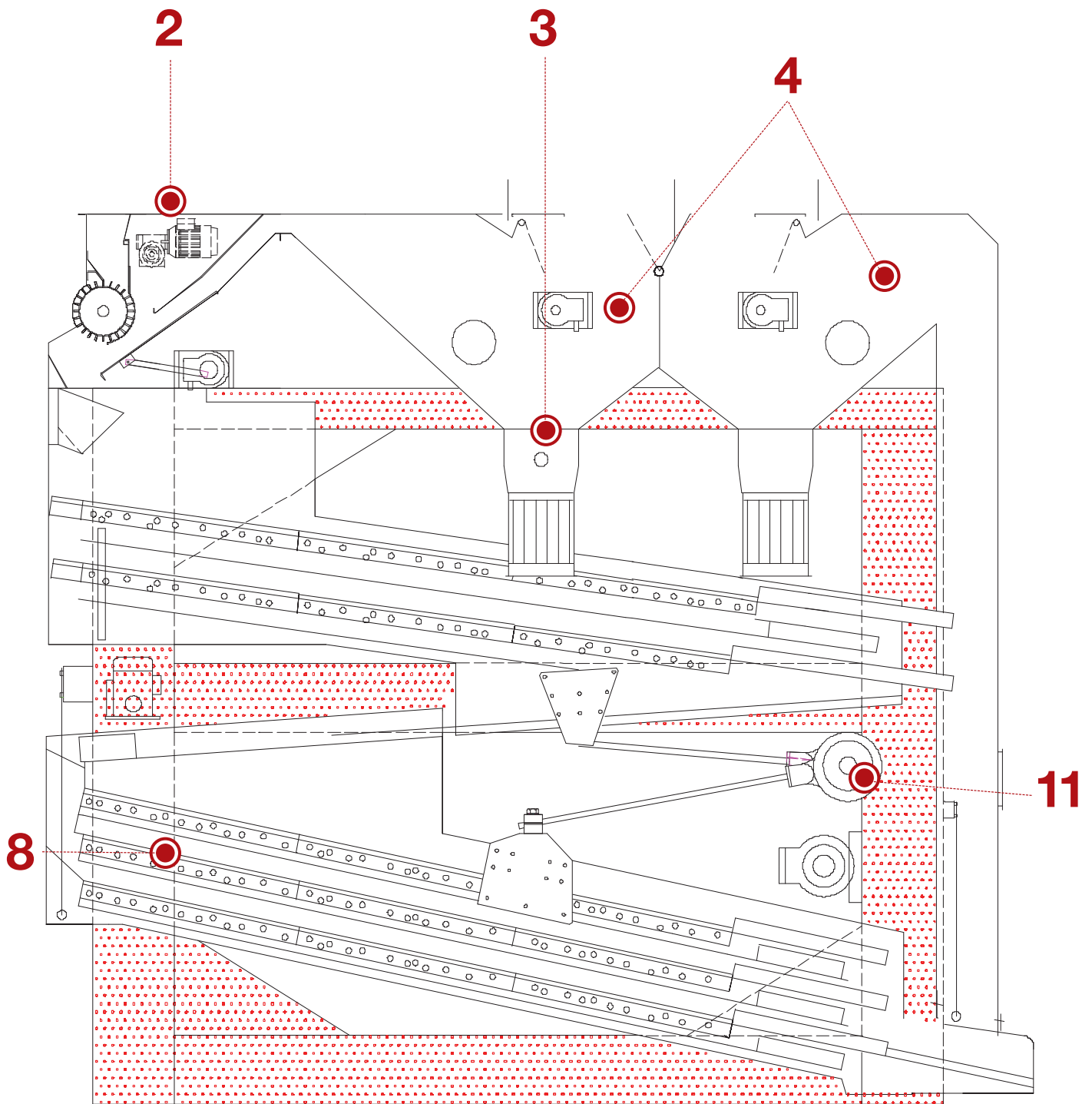

## **8** AKYUREK EXCELL SCREENS FOR ALL PURPOSES

Are Available With Round And Oblong Holes From 0.3 To 25.0 Mm

- Are Also Available As Wire-mesh Screens For Special Products
- Have As Standard Holes In The Screen Plates With Very Small Tolerances, Thus Ensuring Minimum Cleaning Loss
- Are Available In A Standard Size Of 1000 Mm (L) X 1800 Mm (W) = 1.8 M<sup>2</sup>, Which Can Be Used In All Excell Cleaners, Thus Reducing The Number Of Screens Required

## **10** ACCESS TO THE SCREENS

- The Access Hatches Have Snap- Action Locks
- The Hatches Are Small And Hinged At The Bottom
- Rapid Changing Of Screens

## **12** MOTORS

- Are Mounted Externally, Thus Resulting In Rapid And Simple Adjustment And Replacement Of The V-belts

## **14** TOTALLY INCLOSED CLEANERS

- The Cleaners Are Totally Closed
- The Doors Are An Integral Part Of The Waste Pipe System
- Easy And Rapid Access To Replace Outlet Trays When Changing Flow

## **15** COVERING OF SCREEN SECTIONS

- Both Screen Sections Are Covered With Galvanised Plate With Rubber Inspection Hatches
- There Is Dust Extraction From Each Screen Box

## **19** WEAR PLATES

- Replaceable Pehd 1000 And Hardox Wear Plates Are Located At All Exposed Surfaces
- Easy To Replace
- Repair Intervals Are Extended
- Repair Costs Are Reduced
- Are Moisture-resistant And Insect- Resistant, And Approved By The Food Industry
- Are Constructed With Replaceable Wear Plates And Screen Runners In Exposed Areas
- Have A Long Lifetime Due To The Fact That The Plywood Easily Copes With The Vibrations Of The Screen Box
- Give Less Resonance Owing To The Use Of Plywood, Thus Resulting In A Better Working Environment

## **9** BALL BOX

Ensures Efficient Cleaning Of Screens By Means Of Rubber Balls Which Are Food- Grade Approved

- Can Maintain The Cleaning Effect At Extremely Low Temperatures As The Rubber Balls Are Moulded In A Material Particularly Well-suited To The Task
- Is Cast In One Piece In Order To Prevent Trapped Seeds, Etc. (Self-cleaning)
- Is Separately Mounted In The Screen Box, Which Enables A Quick Change Of Screens Without Removing The Ball Boxes

## **11** BALANCED ECCENTRIC SYSTEM

- Is Fitted With Counterweights That Ensure Smooth Running
- Results In Minimum Stress On Buildings And Steel Structures
- Is Fitted With »heavy Duty« Bearings
- Ensures Maximum Utilisation Of The Cleaning Effect Of The Screens Owing To Care- Fully Matched Stroke And Speed Of Rotation

## **13** SUSPENSION OF SCREEN BOXES

- The Screen Boxes Are Suspended In Rosta Suspension Units With Moveable Parts In Rubber
- Prevents Transmission Of Vibrations To Buildings And Other Machines
- Ensures That The Machine Can Be Located Almost Any-Where Without Expensive Foundations Needing To Be Established
- Balancing Of The Dynamic Forces In The Machine Ensures Extended Operation Without Repair

## **16** SAMPLING

- Handy Sampler
- Easy To Take Samples From The Various Outlet Trays

## **17** RECIRCULATING POST-SUCTION UNIT

- Ensures The Highest Purity Of The Product By Means Of The Extraction Of Lightweight Particles Such As Empty Kernels, Husks And Dust, Etc. When The Product Exits The Cleaner Via The Exhaust Unit

## **18** EXHAUST UNIT FOR CLEAN PRODUCT

- Distributes The Recirculated Air So That All Clean Product Is Aerated
- The Remaining Lightweight Kernels And Dust Particles Are Separated
- Fresh Air Is Supplied At The Same Rate As The Air That Is Removed In The Mini-cyclone

# UNIVERSAL CLEANERS

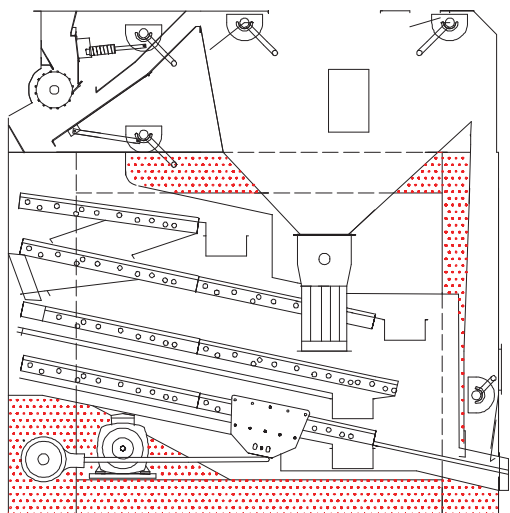

EXCELL 242

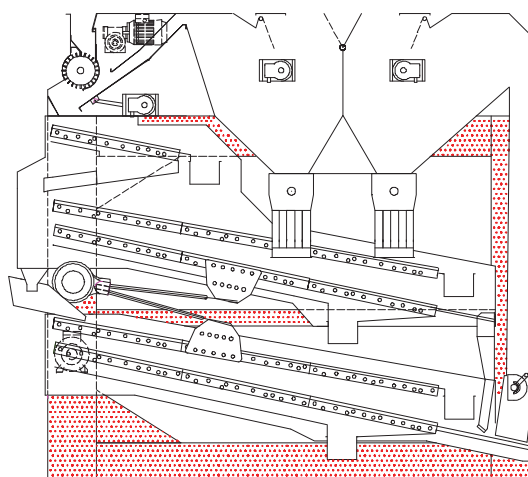

EXCELL 245

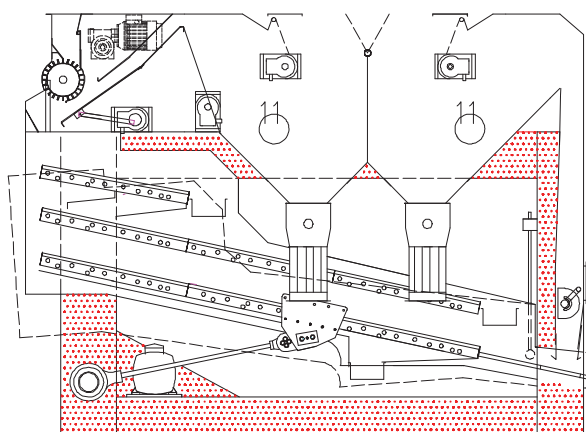

EXCELL 243

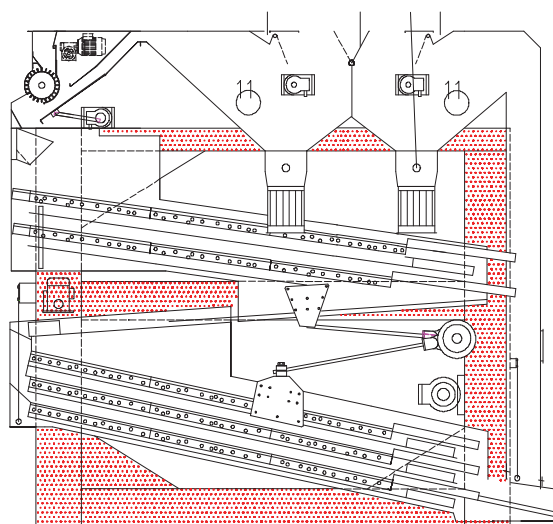

EXCELL 246

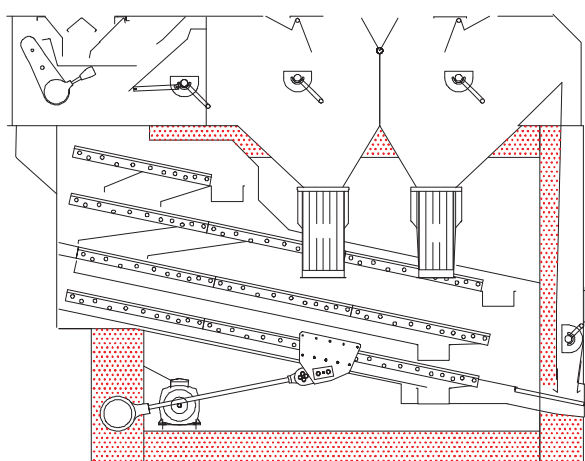

EXCELL 244-1

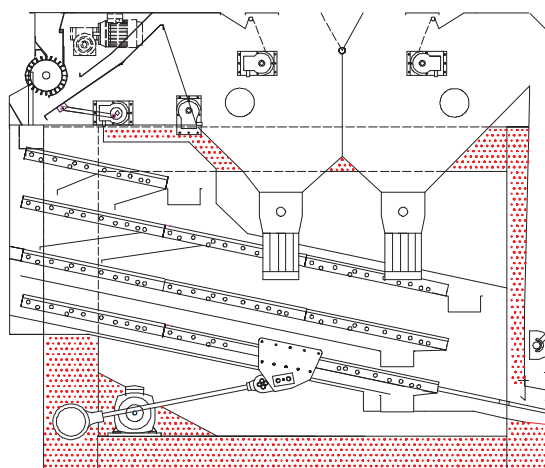

EXCELL 244

# UNIVERSAL CLEANERS

UNIVERSAL Pre-Cleaner	242	243.1 & 243.2	244.1 & 244.2	245	246
<b>CAPACITY GUIDE</b> (max. 20% moisture):					
<b>Pre-cleaning:</b>	tph	tph	tph	tph	tph
Wheat and barley	30	45	50	60	100
Rape seed	25	35	40	50	90
Maize	25	35	40	50	90
Peas	25	35	40	50	90
Paddy Rice	12,5	17,5	20-25	30-35	45-50
Sunflower (14% moisture content)	12,5	17,5	20-26	30-36	45-51
<b>Fine Cleaning:</b> (max. 15% moisture content)					
Malting barley	3-5 t/h	5-8 t/h	6-10 t/h	10-15 t/h	15-25 t/h
Seed Grain	1-3 t/h	3-5 t/h	4-6 t/h	6-8 t/h	8-12 t/h
Rape Seed (98% purity)	1-3 t/h	3-6 t/h	4-6 t/h	6-8 t/h	8-12 t/h
Maize and peas	1-3 t/h	3-4 t/h	4-5 t/h	6-8 t/h	20 t/h
<b>Total screen area:</b>	5 m <sup>2</sup>	7 m <sup>2</sup>	10 m <sup>2</sup>	13 m <sup>2</sup>	15 m <sup>2</sup>
<b>Overall dimensions:</b>					
Height (without fan)	2245 mm	2245 mm	2565 mm	2895 mm	3230 mm
Length	2235 mm	3012 mm	3012 mm	3270 mm	3625 mm
Width (incl. motor)	1940 mm	1913 mm	1913 mm	2300 mm	1958 mm
<b>Motors</b>					
Screens	1.5 kW	2.2 kW	2.2 kW	1.5 kW	1.1 kW
Fan	5.5 kW	5.5 kW	7.50 kW	7.50 kW	11.00kW
Feeding roller	0.75 kW	0.75 kW	0.75 kW	1.1 kW	2.2 kW
<b>Air volume:</b>					
Pre- and after suction	6400 m <sup>3</sup>	10600 m <sup>3</sup>	10600 m <sup>3</sup>	11000 m <sup>3</sup>	15000 m <sup>3</sup>
<b>Weight</b>					
Freight volume 11 m <sup>3</sup>	1610 kg	1935 kg	2140 kg	2310 kg	3035 kg
	11 m <sup>3</sup>	15 m <sup>3</sup>	17 m <sup>3</sup>	22 m <sup>3</sup>	25 m <sup>3</sup>