

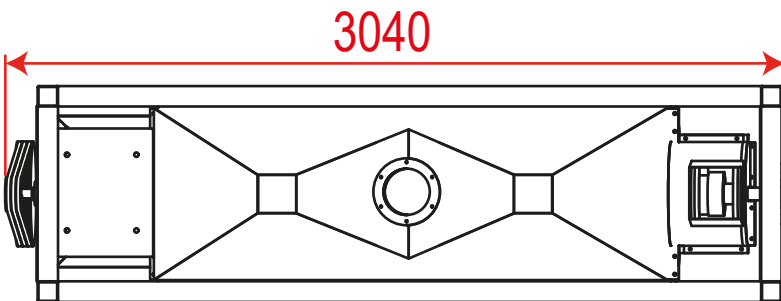

POLISHING MACHINE AK 50-1

Polishing Machine

Continuous Friction Polisher is able to provide polished look on seed lot. Process takes place in drum body of the equipment; Drum surface is perforated screen and within drum screw flights made of soft material conveys the seed from entrance inlet to exit outlet . During this conveying process seed friction takes place and fine dust leaves the surface of the seed through perforated drum and exits from bottom chute. At the entrance inlet Aspiration unit located on machine removes initial dust with suction. Adding value to your commodity by polished look, increased the visual quality of seed.

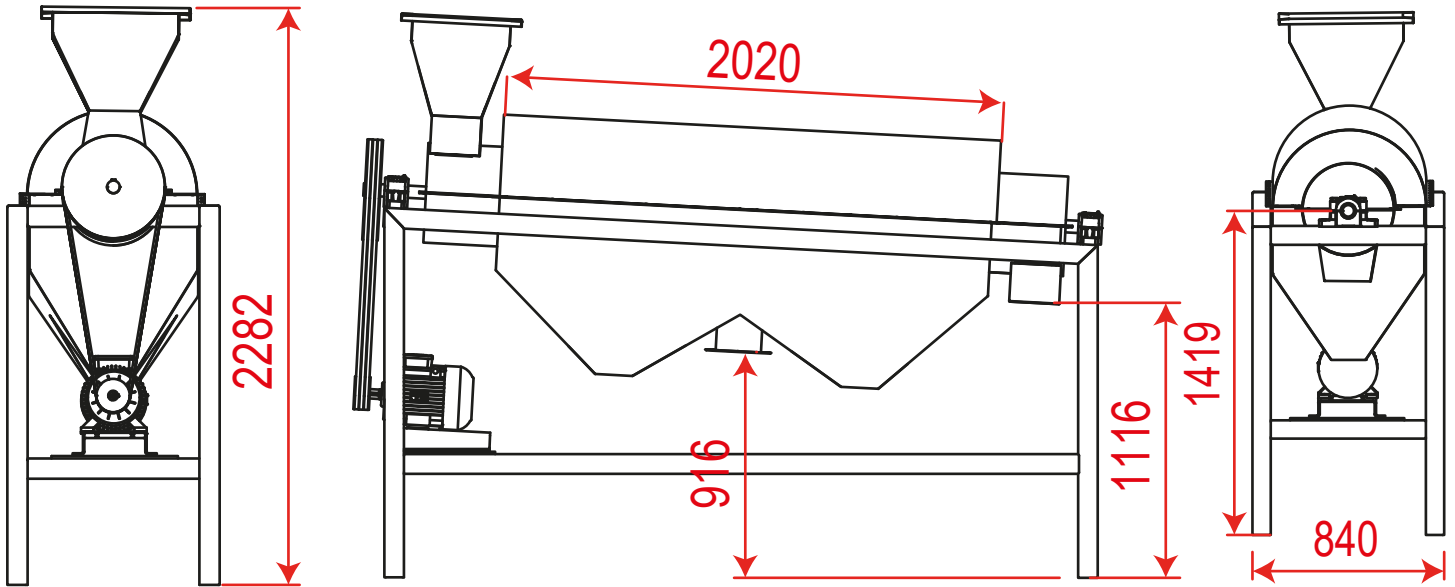

CAPACITY	
Corn	6-7 Ton
Green Mung Beans	5-6 Ton
Beans	6-7 Ton
Sunflower	4-5 Ton
Drive Motor	5.5 kW
Aspirator	2.2 kW



Polishing Machine AK 50-1

POLISHING MACHINE AK 50-1

